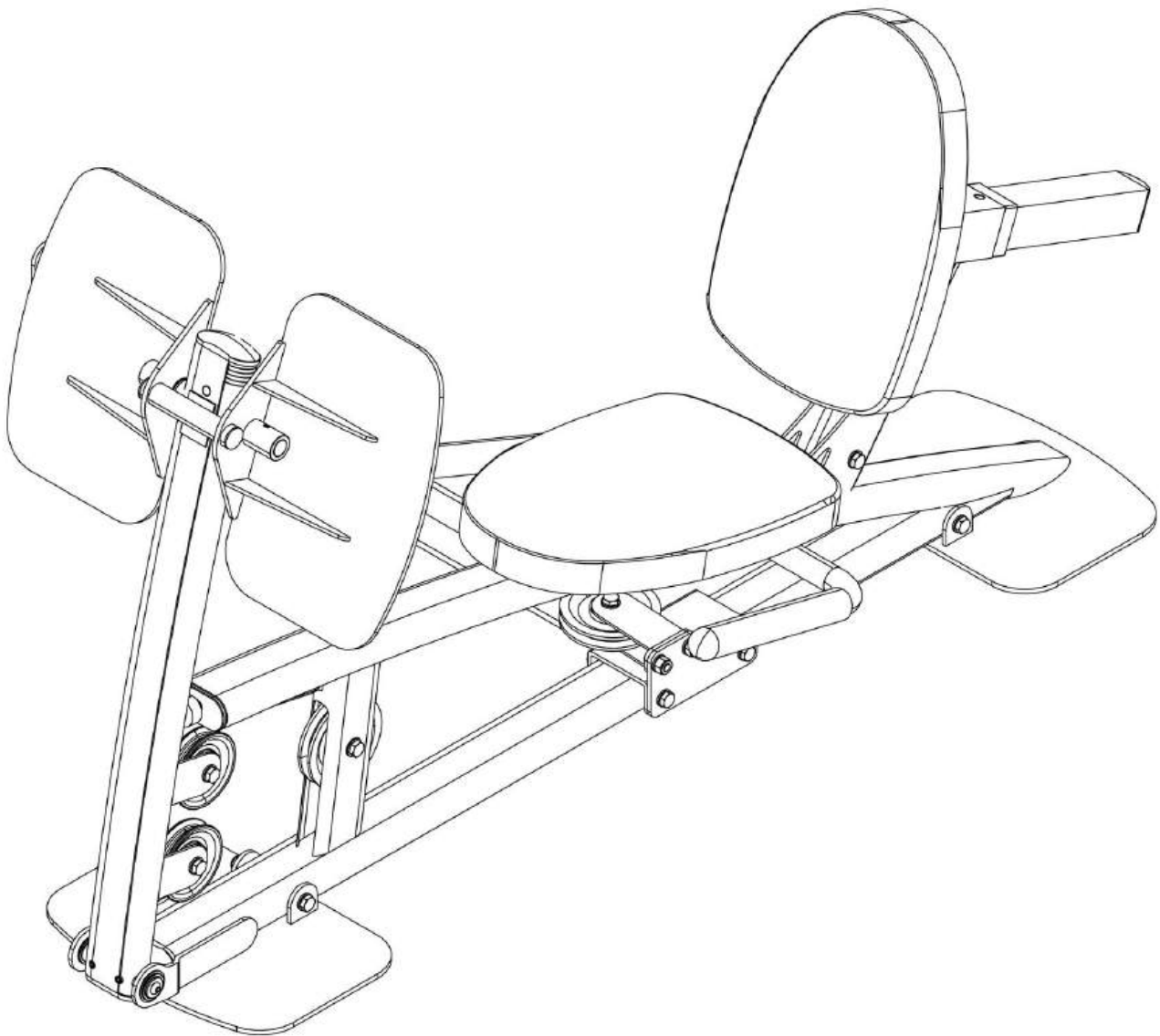


# POWERLINE®



**PLPX**

**OWNER'S MANUAL**

# Before You Begin

Thank you for purchasing the Powerline Leg Press. This piece is part of the Powerline line of quality strength training machines, which let you target specific muscle groups to achieve better muscle tone and overall body conditioning.

---

## Unpacking the Equipment

The Powerline Leg Press is carefully tested and inspected before shipment. We have shipped the unit in several pieces that require assembly. Ask for assistance during the assembly process.

Carefully unpack the boxes and lay the pieces on the floor near the area where you plan to use the equipment.

When you attach the Leg Press attachment, leave all nuts and bolts hand tight, until the last step is complete. Then go back and wrench tighten all nuts and bolts.

Be careful to assemble all components in the sequence presented in this guide.

If any items are missing, contact the dealer from whom you purchased the unit or call Body-Solid Customer Service at 1-800-833-1227.

### **CAUTION: To set up this unit, you will need assistance.**

You must review and follow the instructions in this Owner's Manual. If you do not assemble and use according to these guidelines, you could void the Powerline warranty.

---

**CAUTION:**  
Obtain assistance.  
Review the Installation Requirements before proceeding with the following steps.

### **Installation Requirements:**

Set up on a solid, flat surface. A Smooth, flat surface under the machine helps keep it level. A level machine has fewer malfunctions.

Provide ample space around the machine. Open space around the machine allows for easier access.

**NOTE:** With so many assembled parts, proper alignment and adjustment is critical. While tightening the nuts and bolts, be sure to leave room for adjustments.

Insert all bolts in the same direction. For aesthetic purposes, insert all bolts in the same direction unless specified (in text or illustrations) to do otherwise.

Leave room for adjustments. Tighten fasteners such as bolts, nuts, and screws so the unit is stable, but leave room for adjustments. Do not fully tighten fasteners until instructed in the assembly steps to do so.

Fill out and mail warranty card.

# Important Safety Information

Before beginning any fitness program, you should obtain a complete physical examination from your physician.

Il est conseillé de subir un examen médical complet avant d'entreprendre tout programme d'exercice.  
Si vous avez des étourdissements ou des faiblesses, arrêtez les exercices immédiatement.

Antes de comenzar cualquier programa de ejercicios, deberías tener un examen físico con su doctor.

---

## When using exercise equipment, you should always take basic precautions, including the following:

- Read all instructions before using the unit. These instructions are written to ensure your safety and to protect the unit.
- Do not allow children on or near the equipment.
- Use the equipment only for its intended purpose as described in this guide. Do not use accessory attachments that are not recommended by the manufacturer. Such attachments might cause injuries.
- Wear proper exercise clothing and shoes for your workout, no loose clothing.
- Use care when getting on or off the unit.
- Do not overexert yourself or work to exhaustion.
- If you feel any pain or abnormal symptoms, stop your workout immediately and consult your physician.
- Never operate unit when it has been dropped or damaged. Return the equipment to a service center for examination and repair.
- Never drop or insert objects into any opening in the equipment.
- Always check the unit before each use. Make sure that all fasteners are secure and in good working condition.
- Do not use the equipment outdoors or near water.

## Personal Safety During Assembly

If possible have a qualified dealer assemble the equipment.

- Before beginning assembly, please take the time to read the instructions thoroughly.
- Read each step in the assembly instructions and follow the steps in sequence. Do not skip ahead. If you skip ahead, you may learn later that you have to disassemble components and that you may have damaged the equipment.
- Assemble and operate on a solid, level surface. Locate the unit a few feet from the walls or furniture to provide easy access.

This unit is designed for your enjoyment. By following these precautions and using common sense, you will have many safe and pleasurable hours of healthful exercise.

After assembly, you should check all functions to ensure correct operation. If you experience problems, first recheck the assembly instructions to locate any possible errors made during assembly. If you are unable to correct the problem, call the dealer from whom you purchased the machine or call 1-800-833-1227 for the dealer nearest you.

## Obtaining Service

Please use this Owner's Manual to make sure that all parts have been included in your shipment. When ordering parts, you must use the key number, part number, and description from this Owner's Manual. Use only Powerline replacement parts when servicing this machine. Failure to do so will void your warranty and could result in personal injury.

For information about product operation or service, check out the official Body-Solid web site at:  
[www.bodysolid.com](http://www.bodysolid.com)

or contact an authorized Powerline dealer or a Powerline factory-authorized service company or contact Body-Solid customer service at one of the following:

Toll Free: 1-800-556-3113  
Phone: 1-708-427-3555 ext.5  
Fax: 1-708-427-3556  
E-mail: [service@bodysolid.com](mailto:service@bodysolid.com)

Or write to: Body-Solid, Inc.  
Service Department  
1900 S. Des Plaines Ave.  
Forest Park, IL 60130 USA

**Retain this Owner's Manual for future reference. Part numbers are required when ordering parts.**

# Safety Guidelines

Successful resistance training programs have one prominent feature in common...safety. Resistance training has some inherent dangers, as do all physical activities. The chance of injury can be greatly reduced or completely removed by using correct lifting techniques, proper breathing, maintaining equipment in good working condition, and by wearing the appropriate clothing.

---

- 1. It is highly recommended that you consult your physician before beginning any exercise program. This is especially important for individuals over the age of 35, or persons with pre-existing health problems.**
- 2. Always warm up before starting a workout. Try to do a total body warm up before you start. It is especially important to warm up the specific muscle groups you are going to be using. This can be as simple as performing a warm up set of high repetitions and light weight for each exercise.**
- 3. Use proper form. Focus on only working the muscle groups intended for the exercise you are doing. If there is strain elsewhere, you may need to re-evaluate the amount of weight that is involved with the lift. Keeping proper form also includes maintaining control through an entire range of motion.**
- 4. Breathe properly. Inhale during the eccentric phase of the exercise, and exhale during the lifting, or concentric phase. Never hold your breath during any part of an exercise.**
- 5. Always wear the appropriate clothing and shoes when exercising. Wearing comfortable athletic shoes with good support and suitable, breathable clothing will reduce the risk of injury.**
- 6. Maintaining equipment in proper operating condition is of utmost importance for a safe resistance training program. Pulleys and cables should be checked for wear frequently and replaced as needed. Equipment should be lubricated as indicated by the manufacturer.**
- 7. Read and study all warning labels on this machine. It is absolutely necessary that you familiarize yourself and all others with the proper operation of this machine prior to use.**
- 8. Keep hands, limbs, loose clothing and long hair well out of the way of all moving parts.**
- 9. Do not attempt to lift more weight than you can control safely.**
- 10. Inspect the machine daily for loose or worn parts. If a problem is found do not allow the machine to be used until all parts are tightened or worn or defective parts are repaired or replaced.**

# Assembly Instructions

## Professional installers are highly recommended!

However, if you acquire the appropriate tools, obtain assistance, and follow the assembly steps sequentially, the process will take time, but is fairly easy.

### Required Tools:

9/16" Open-End Wrench  
11/16" Open-End Wrench  
3/4" Open-End Wrench  
13/16" Open-End Wrench

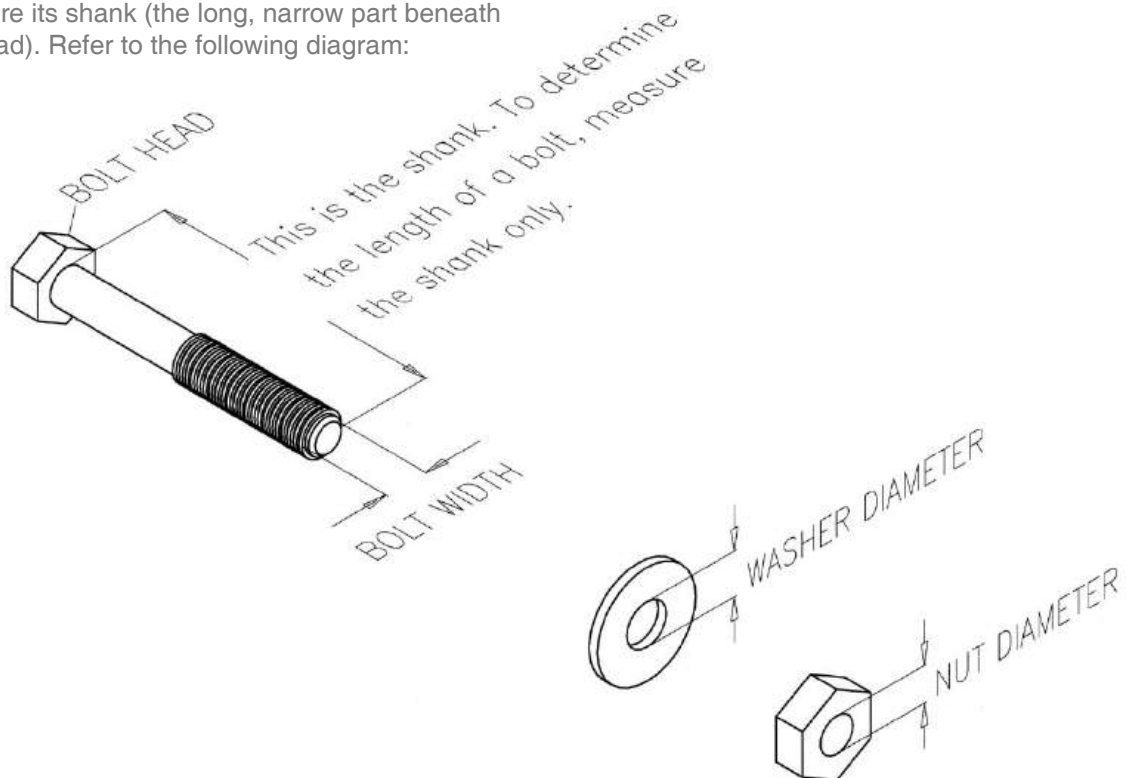
### Assembly Tips:

Read all "Notes" on each page before beginning each step.

While you may be able to assemble this unit using the illustrations only, important safety notes and other tips are included in the text.

Some pieces may have extra holes that you will not use. Use only those holes indicated in the instructions and illustrations.

NOTE: To find out the length of a particular bolt, measure its shank (the long, narrow part beneath the head). Refer to the following diagram:



### Do not fully tighten bolts until instructed to do so.

Note: After assembly, you should check all functions to ensure correct operation. If you experience problems, first recheck the assembly instructions to locate any possible errors made during assembly. If you are unable to correct the problem, call the dealer from whom you purchased the machine or call 1-800-556-3113 for the dealer nearest you.

**STEP****1**

Be careful to assemble all components in the sequence they are presented.

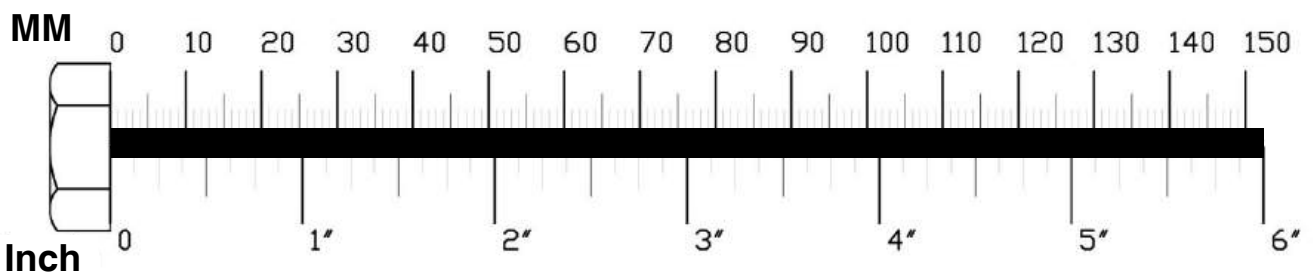
**NOTE:**

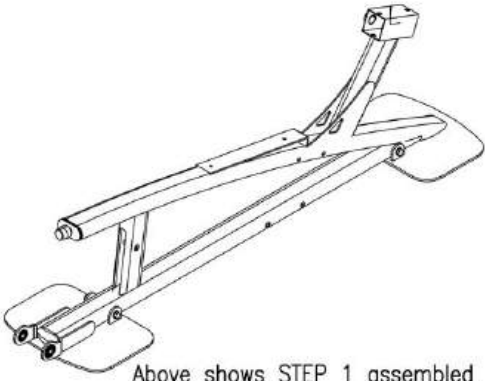
Finger tighten all hardware in this step. Do **NOT** wrench tighten until the end of step 7.

- A. Attach two Base Plates (B) to the Main Frame (A) as shown using:  
**Two 25 (3/8" x 4" hex head bolt)**  
**Four 32 (3/8" washer)**  
**Two 40 (3/8" nylon lock nut)**
- B. Attach End Cap (1) to the front of Main Frame (A) as shown.
- C. Attach Rubber Stop (11)\* and Lock Nut (41)\* into Main Frame (A) as shown.

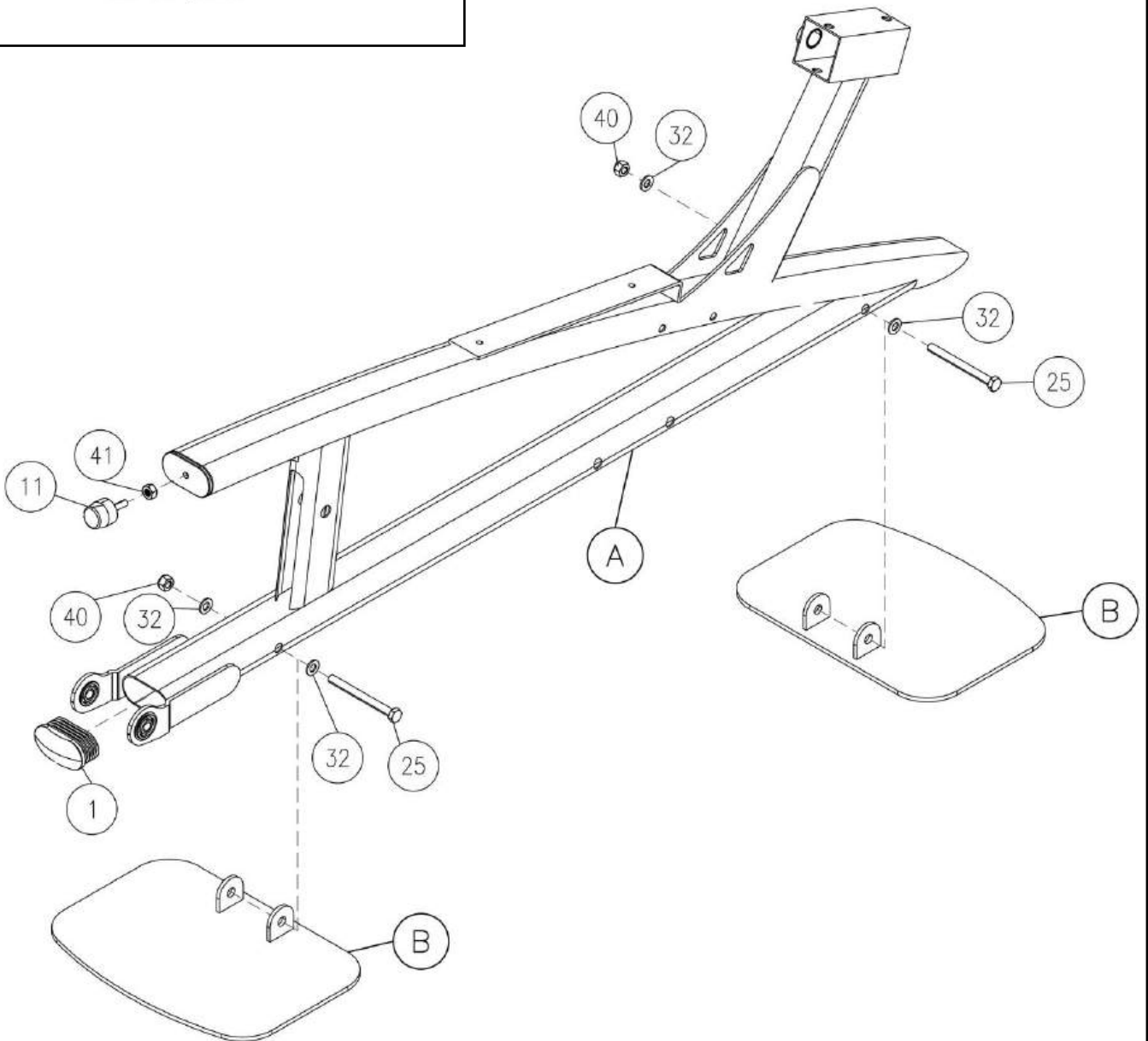
**\*NOTE:**

These parts might be pre-installed.





Above shows STEP 1 assembled and completed.



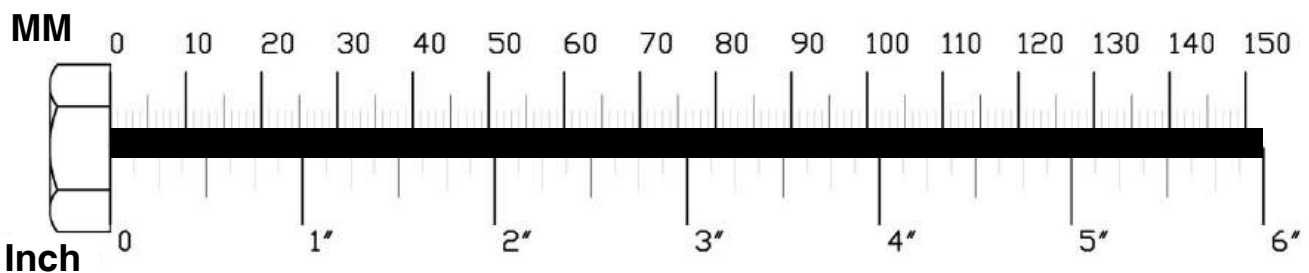
**STEP****2**

Be careful to assemble all components in the sequence they are presented.

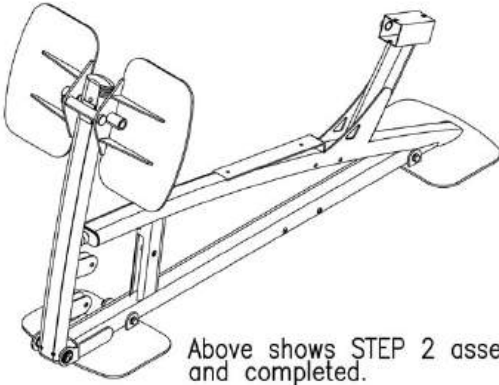
**NOTE:**

Finger tighten all hardware in this step. Do NOT wrench tighten until the end of step 7.

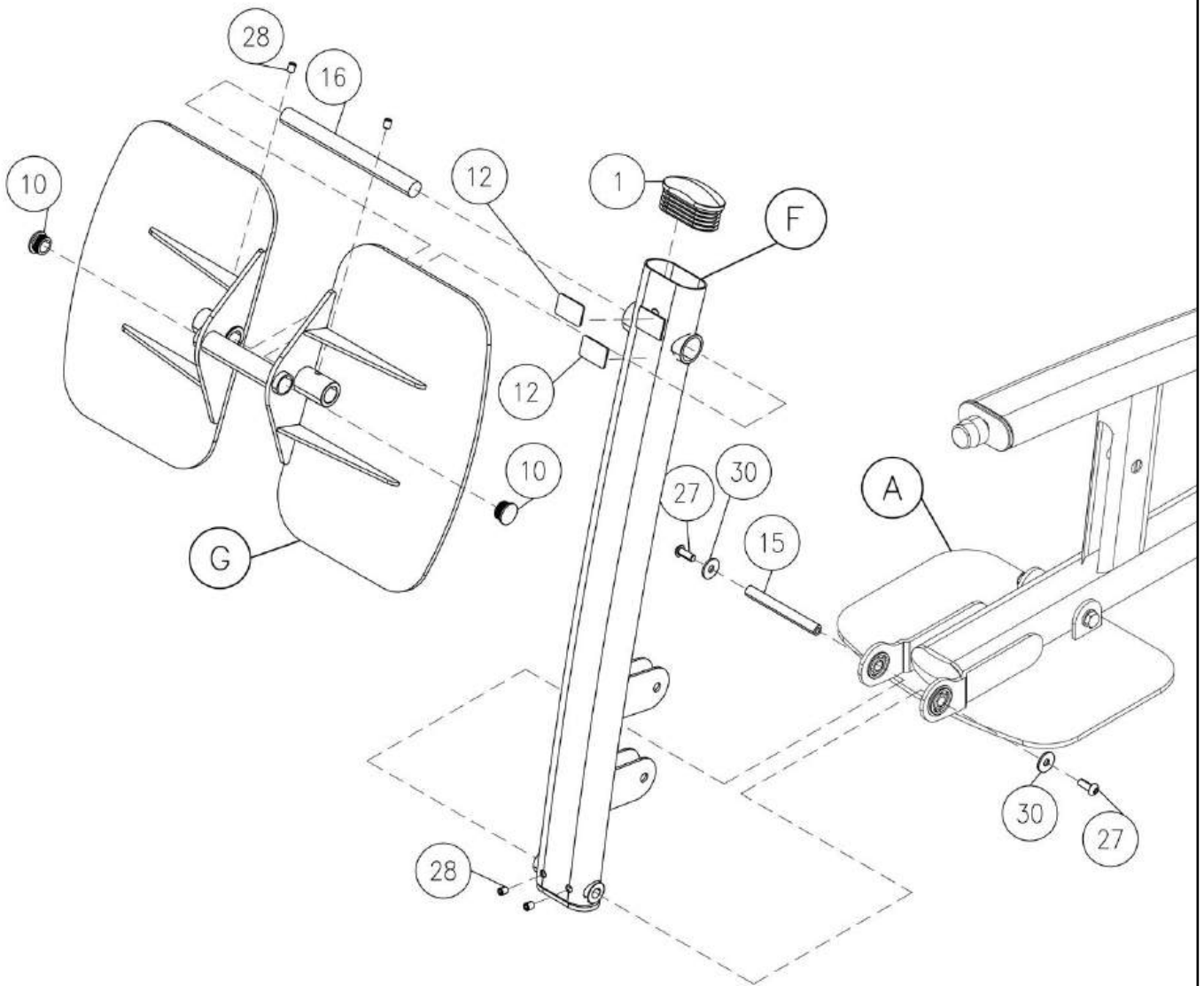
- A. Attach Pivot Arm (F) to Main Frame (A) as shown using Small Shaft (15) and:  
**Two 27 (5/16" x 1/2" flat allen head bolt)**  
**Two 30 (5/16" washer)**
- B. Tighten Allen Head Bolts (28) to keep Small Shaft (15) in place.
- C. Attach Foot Plate (G) onto Pivot Arm (F) as shown using Shaft (16).  
Tighten Allen Head Bolts (28) to keep Shaft (16) in place.
- D. Attach End Cap (1) to Pivot Arm (F) as shown.  
Attach two Rubber Pads (12) to Pivot Arm (F) as shown.  
Attach Round End Caps (10) to Foot Plate (G).



STEP  
**2**



Above shows STEP 2 assembled and completed.

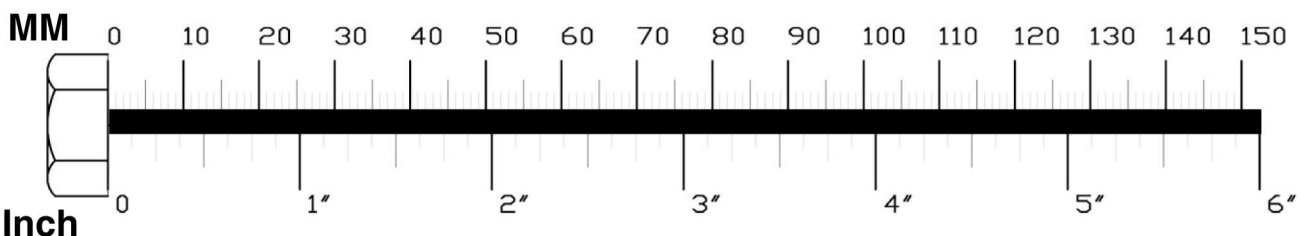


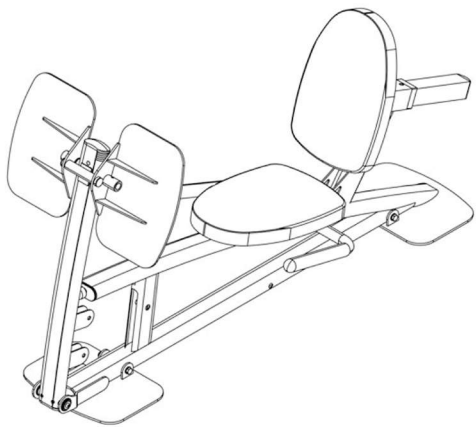
Be careful to assemble all components in the sequence they are presented.

**NOTE:**

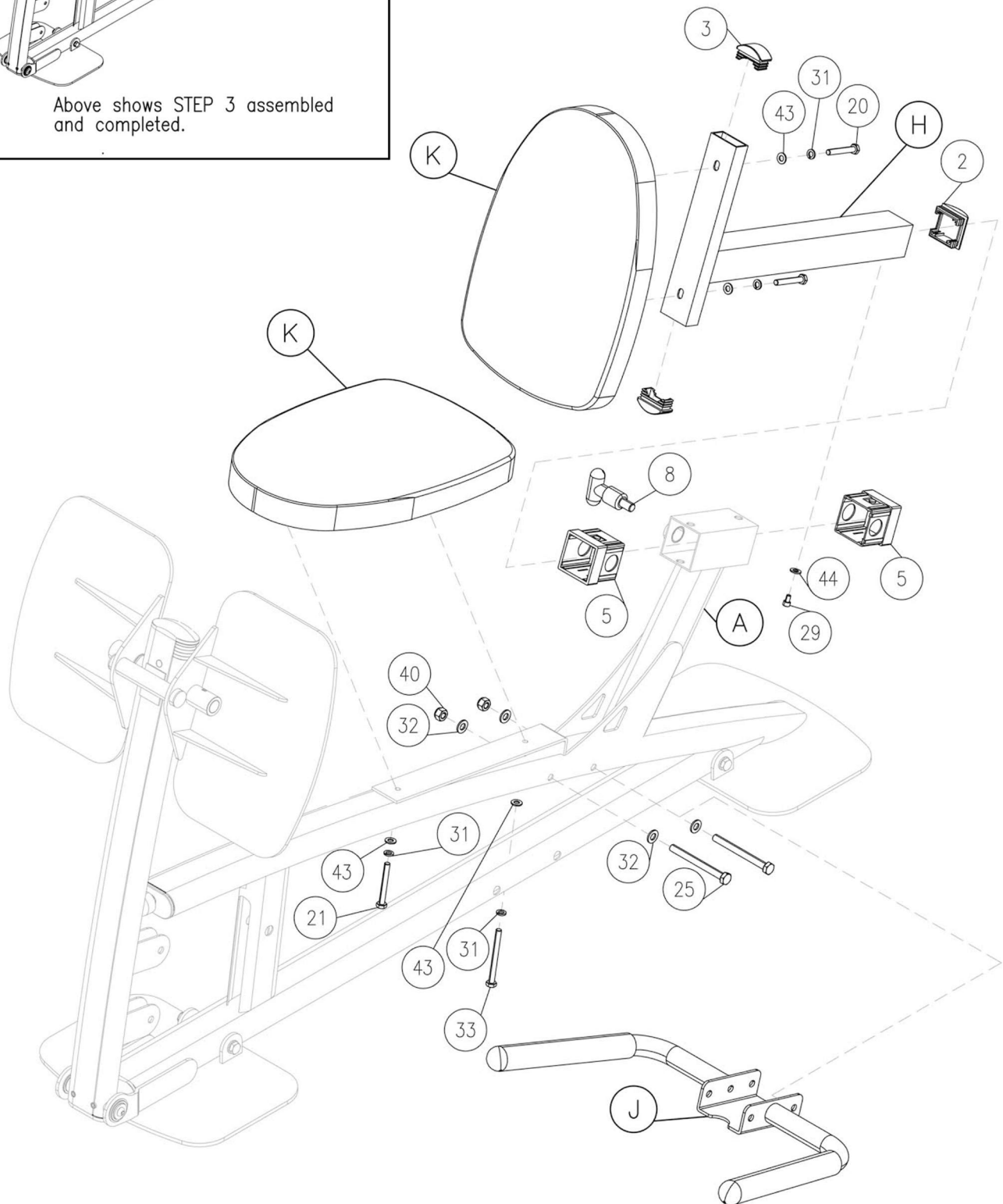
Finger tighten all hardware in this step. Do NOT wrench tighten until the end of step 7.

- A. Attach Handles (J) to Main Frame (A) as shown using:  
**Two 25 (3/8" x 4" hex head bolt)**  
**Four 32 (3/8" washer)**  
**Two 40 (3/8" nylon lock nut)**
- B. Attach Seat Pad (K) to Main Frame (A) as shown using:  
**One 21 (5/16" x 2 1/4" hex head bolt)**  
**One 33 (5/16" x 3 1/2" hex head bolt)**  
**Two 43 (5/16" washer)**  
**Two 31 (5/16" spring lock washer)**
- C. Insert two Plastic Bushing (5) into Main Frame (A) as shown.
- D. Attach Back Pad (K) to Back Pad Frame (H) as shown using:  
**Two 20 (5/16" x 1 1/2" hex head bolt)**  
**Two 3 (5/16" washer)**  
**Two 31 (5/16"**
- E. Insert Back Pad Frame (H) into the Plastic Bushing (5) in Main Frame (A) as shown. Hold in place with T-Shaped Pop Pin (8) as shown. To stop Back Pad Frame (H) from sliding all the way out insert:  
**One 29 (5/16" x 1/2" socket head bolt)**  
**One 44 (5/16" spring lock washer)**
- F. Insert two End Caps (3) into Back Pad Frame (H) as shown. Insert End Cap (2) into Back Pad Frame (H) as shown.





Above shows STEP 3 assembled and completed.



## 4

Be careful to assemble all components in the sequence they are presented.

**NOTE:**

Finger tighten all hardware in this step. Do NOT wrench tighten until the end of step 7.

**NOTE:**

To mount the Leg Press on the left side of the gym use Step 4.

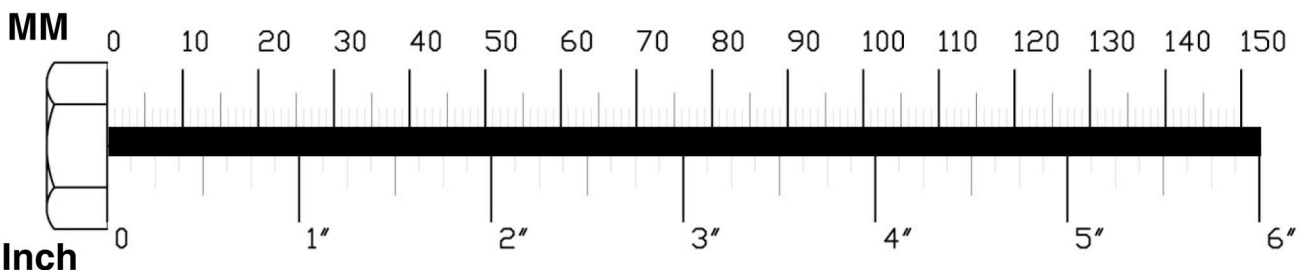
To mount the Leg Press on the right side of the gym go to Step 5.

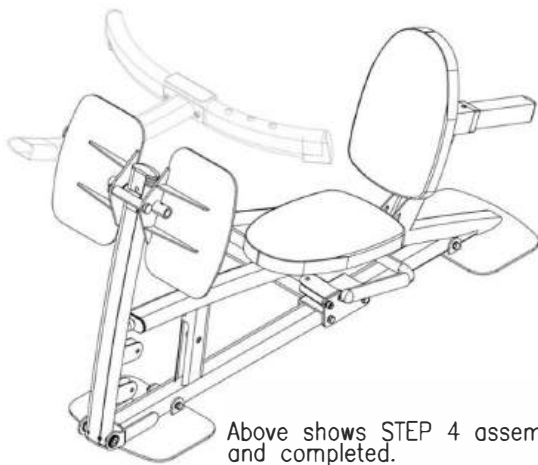
- A. Attach Main Frame Connection (C) and Plate (D) to Main Frame (A) using:  
**Two 42 (3/8" x 4 3/8" hex head bolt)**  
**Four 32 (3/8" washer)**  
**Two 40 (3/8" nylon lock nut)**
- B. Attach Pulley Holder (E) to Plate (D) using:  
**Two 22 (3/8" x 1" hex head bolt)**  
**Four 32 (3/8" washer)**  
**Two 40 (3/8" nylon lock nut)**
- C. Attach Main Frame Connection (C) to the main frame of your gym as shown using:  
**Three 42 (3/8" x 4 3/8" hex head bolt)\***  
**Six 32 (3/8" washer)**  
**Three 40 (3/8" nylon lock nut)**

**\*NOTE:**

Two of these bolts (42) are already on your gym, with hardware.

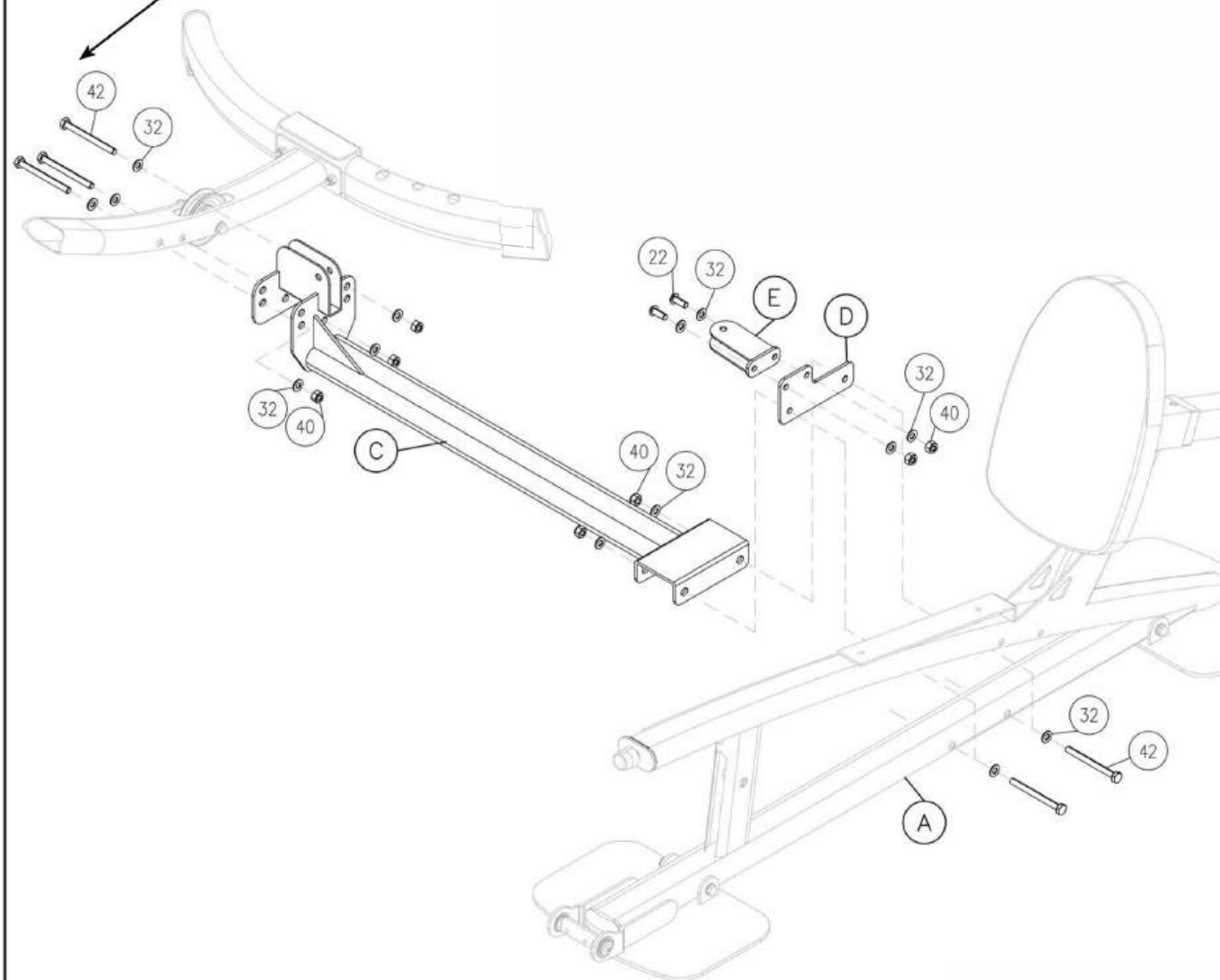
There is One bolt (42), Two washers (32), and One nylon lock nut (40) included with the Leg Press.





Above shows STEP 4 assembled and completed.

Use two original bolts from your gym.



Be careful to assemble all components in the sequence they are presented.

## NOTE:

Finger tighten all hardware in this step. Do Not wrench tighten until the end of step 7.

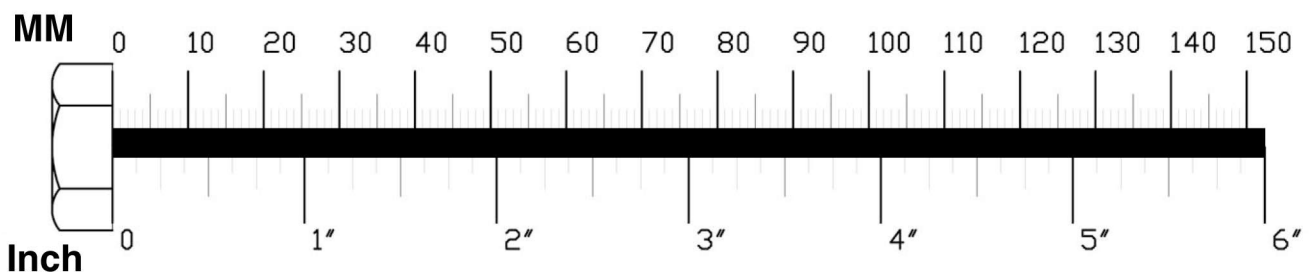
## NOTE:

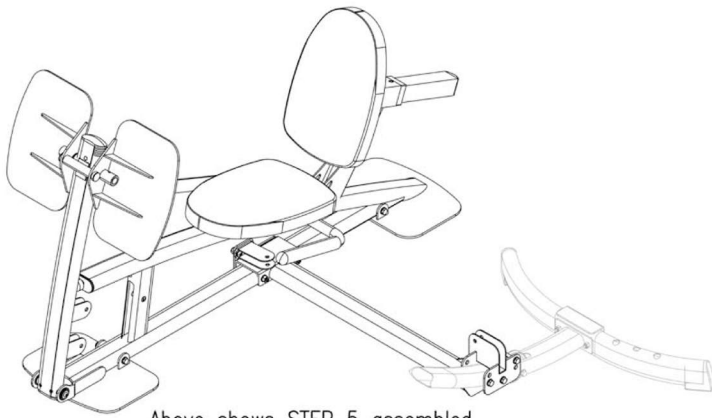
To mount the Leg Press on the right side of the gym use this step.

- A. Attach Main Frame Connection (C) and Plate (D) to Main Frame (A) using:  
**Two 42 (3/8" x 4 3/8" hex head bolt)**  
**Four 32 (3/8" washer)**  
**Two 40 (3/8" nylon lock nut)**
- B. Attach Pulley Holder (E) to Plate (D) using:  
**Two 22 (3/8" x 1" hex head bolt)**  
**Four 32 (3/8" washer)**  
**Two 40 (3/8" nylon lock nut)**
- C. Attach Main Frame Connection (C) to the main frame of your gym as shown using:  
**Three 42 (3/8" x 4 3/8" hex head bolt)\***  
**Six 32 (3/8" washer)**  
**Three 40 (3/8" nylon lock nut)**

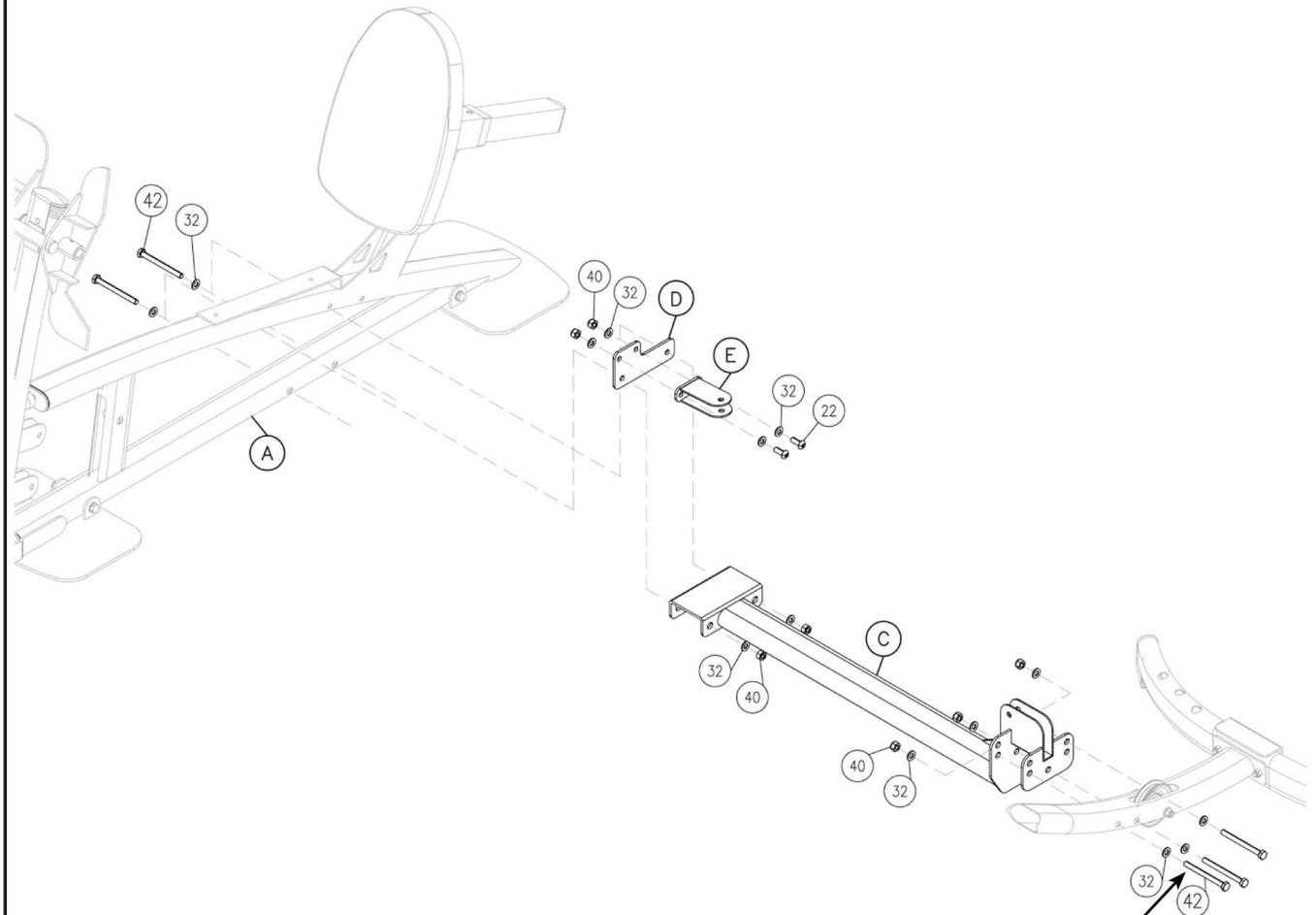
## \*NOTE:

Two of these bolts (42) are already on your gym, with hardware.  
 There is One bolt (42), Two washers (32), and One nylon lock nut (40) included with the Leg Press.





Above shows STEP 5 assembled and completed.



Use two original bolts from your gym.

**STEP****6**

Be careful to assemble all components in the sequence they are presented.

**NOTE:**

Finger tighten all hardware in this step. Do NOT wrench tighten until the end of step 7.

### Leg Press Cable (19)

Stamped Eye End

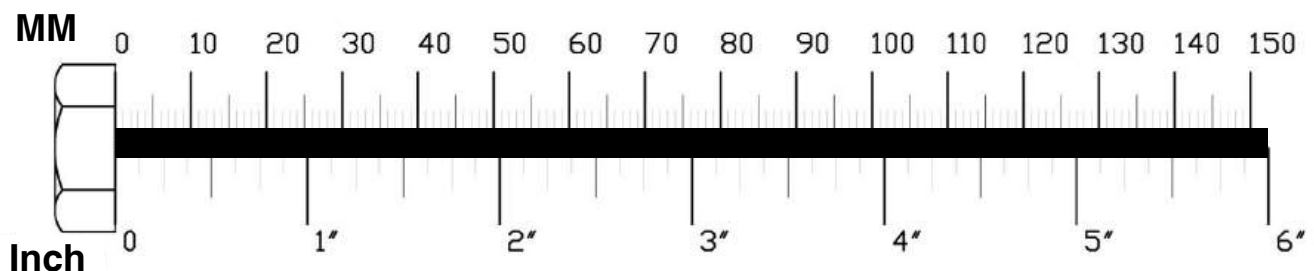
Chain End

**Note:**

Pulleys in this step are 4 1/4" diameter, except where noted in step 6D.

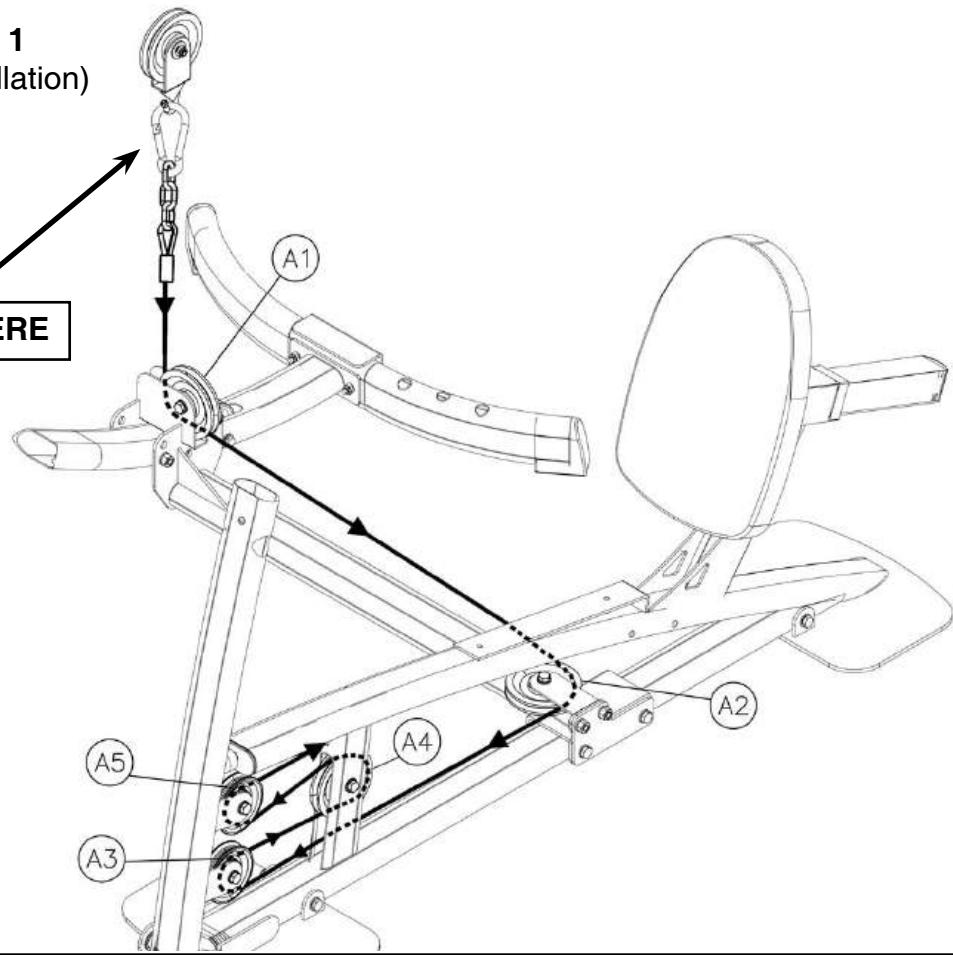
Leave all pulley bolts hand tight until step 7 is completed.

- A. See diagram 1. Begin at the hanging pulley, by removing the old Short Cable that is connected to the frame and hanging pulley. Attach either Stamped Eye End of the Leg Press Cable (19) to the hook on the bottom of the hanging pulley. Route the Leg Press Cable (19) down toward the Lower Main Frame.
- B. See diagram 1. Route Leg Press Cable (19) around Pulley (A1) and install Pulley (A1) into the pulley flanges in the Main Frame Connection (C) as shown in diagram 2 using:  
**One 23 (3/8" x 2" hex head bolt)**  
**Two 32 (3/8" washer)**  
**One 40 (3/8" nylon lock nut)**
- C. See diagram 1. Route Cable (19) along the top of the Main Frame Connection (C) and toward the Main Frame (A) of the Leg Press as shown. Route Cable (19) around Pulley (A2), then see diagram 2, and install Pulley (A2) Pulley Holder (D) as shown using:  
**One 23 (3/8" x 2" hex head bolt)**  
**Two 32 (3/8" washer)**  
**One 40 (3/8" nylon lock nut)**
- D. See diagram 1. Route Cable (90) along the top and through the opening in Main Frame (A) as shown. Route Cable (19) around 3 1/2" Pulley (A3) and install 3 1/2" Pulley (A3) into the bottom pulley flange in Pivot Arm (F) as shown in diagram 2 using:  
**One 23 (3/8" x 2" hex head bolt)**  
**Two 32 (3/8" washer)**  
**One 40 (3/8" nylon lock nut)**

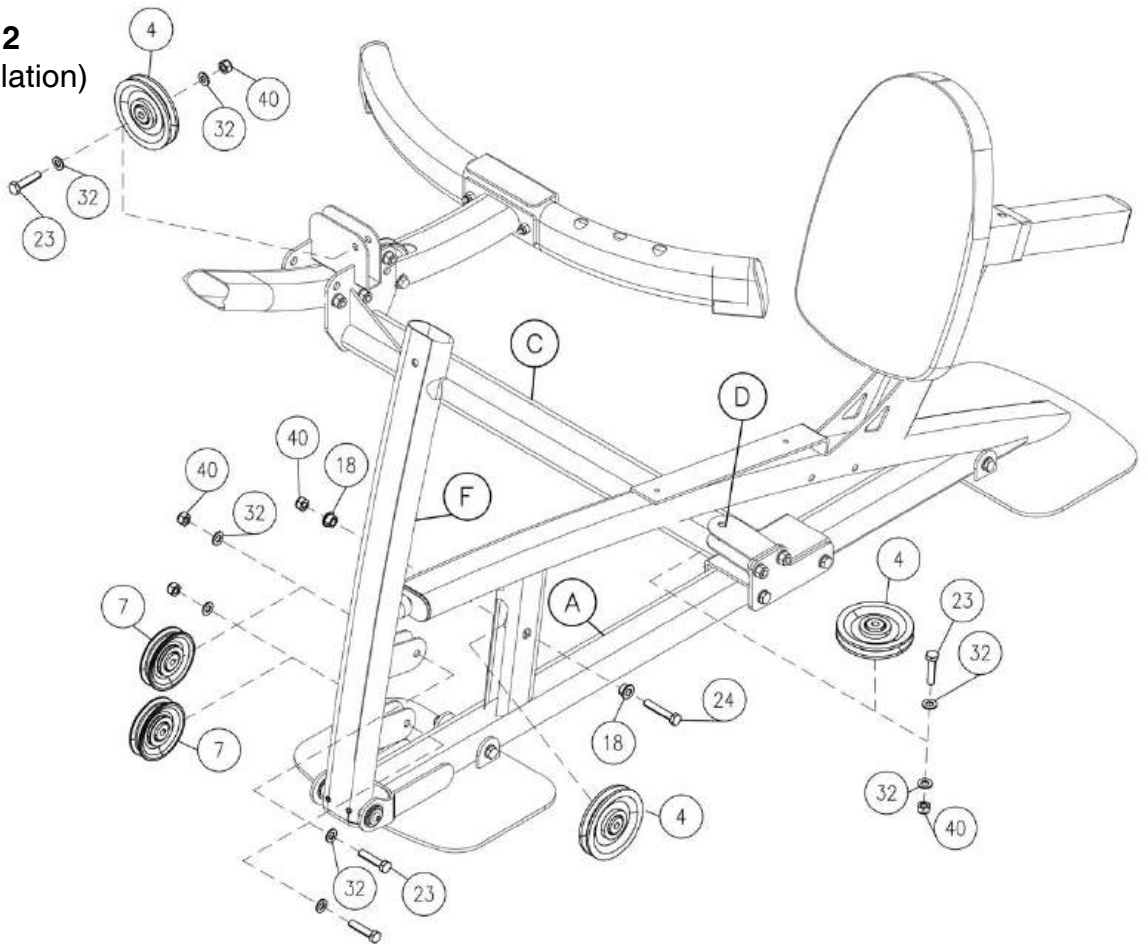


**Diagram 1**  
(cable installation)

**START HERE**



**Diagram 2**  
(pulley installation)



**STEP****7**

Be careful to assemble all components in the sequence they are presented.

**NOTE:**

Finger tighten all hardware in this step. Do NOT wrench tighten until the end of step 7.

### Leg Press Cable (19)

Stamped Eye End

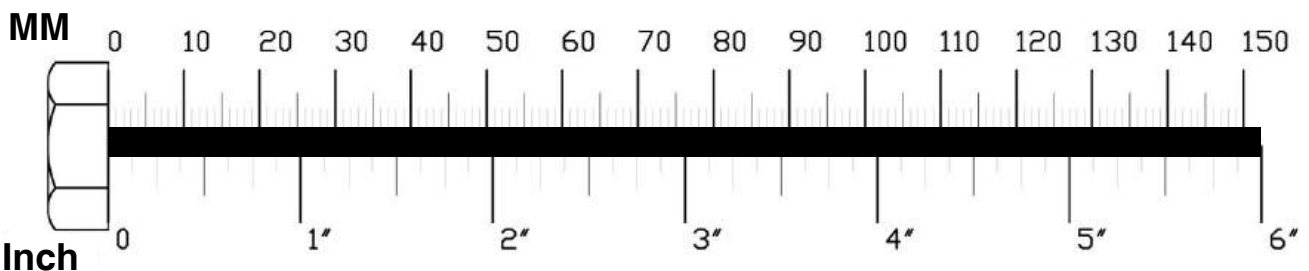
Chain End

**Note:**

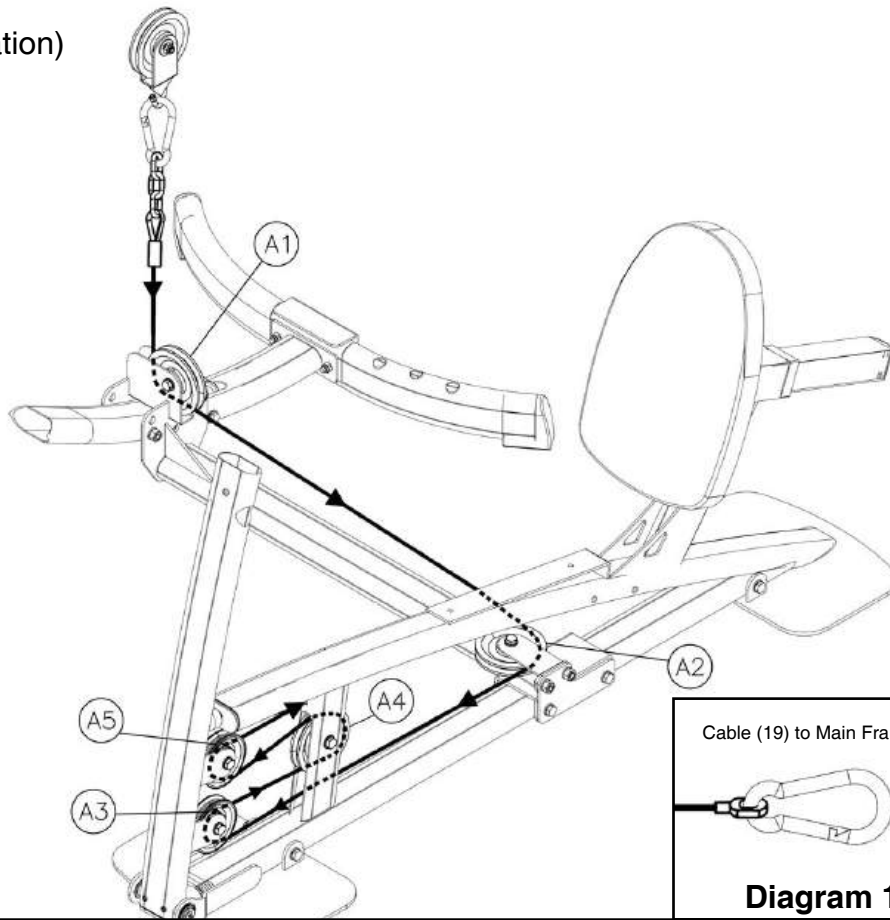
Pulleys in this step are 4 1/4" diameter, except where noted in step 7B.

Leave all pulley bolts hand tight until step 7 is completed.

- A. See diagram 1. Route Cable (19) around Pulley (A4) and install Pulley (A4) into the Main Frame (A) as shown in diagram 2 using:
  - One 24 (3/8" x 2 1/2" hex head bolt)**
  - Two 18 (pulley bushing)**
  - One 40 (3/8" nylon lock nut)**
  
- B. See diagram 1. Route Cable (19) around 3 1/2" Pulley (A5) and install 3 1/2" Pulley (A5) into the top pulley flange in Pivot Arm (F) as shown in diagram 2 using:
  - One 23 (3/8" x 2" hex head bolt)**
  - Two 32 (3/8" washer)**
  - One 40 (3/8" nylon lock nut)**
  
- C. See diagram 1A. Route Cable (19) under the Main Frame (A) and connect to Main Frame (A) with a Snap Link (6).

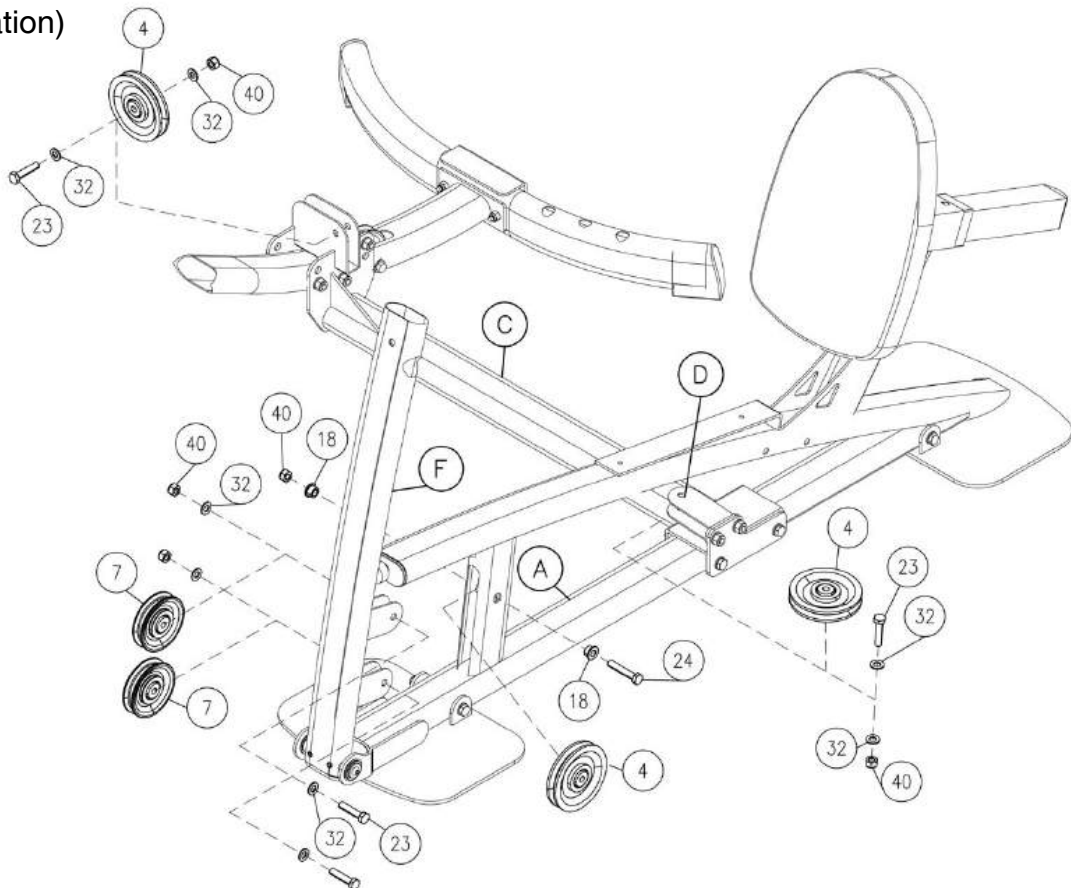


**Diagram 1**  
(cable installation)



**Diagram 1A**

**Diagram 2**  
(pulley installation)



## PLPX Main Frame Parts List

<b>PART#</b>	<b>QTY</b>	<b>KEY#</b>	<b>DESCRIPTION</b>
A	1	PLPMF-A	MAIN FRAME
B	2	PLPBP-B	BASE PLATE
C	1	PLPMFC-C	MAIN FRAME CONNECTION
D	1	PLPP-D	PULLEY HOLDER
E	1	PLPPH-E	PLATE
F	1	PLPPA-F	PIVOT ARM
G	1	PLPFP-G	FOOT PLATE
H	1	PLPBPF-H	BACK PAD FRAME
J	1	PLPH-J	HANDLES
K	2	PLPS/BP-K	SEAT / BACK PAD

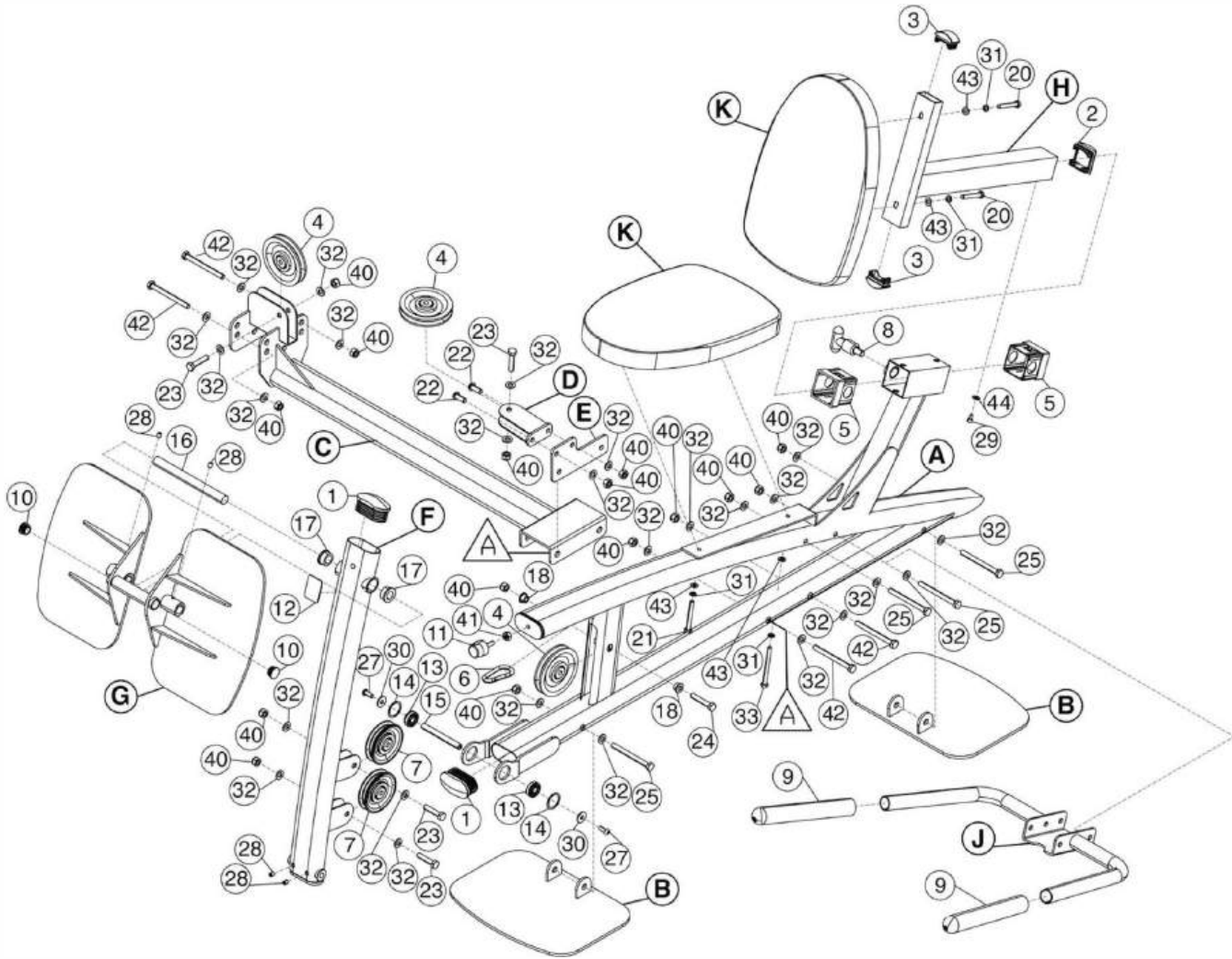
**Key #, Part #, and Description are required when ordering parts.**

# PLPX Hardware List

PART#	QTY	KEY#	DESCRIPTION
1	2	EC1.52	END CAP 1 1/2" X 3"
2	1	EC22	END CAP 2" X 2"
3	2	EC12	END CAP 1" X 2"
4	3	PP4.25X.75	PLASTIC PULLEY 4 1/4"OD X 3/4"W
5	2	PB2X2	PLASTIC BUSHING 2" X 2"
6	1	SNAP	SNAP LINK
7	2	SPP3.5X.75	SMALL PLASTIC PULLEY 3 1/2"OD X 3/4"W
8	1	TPP	T-SHAPPED POP PIN
9	2	RG	RUBBER GRIP
10	2	REC	ROUND END CAP
11	1	RUBST	RUBBER STOP
12	2	RUBPAD	RUBBER PAD
13	2	BEARING	BEARING
14	2	RETRING	RETAINING RING
15	1	SMSHAFT	SMALL SHAFT
16	1	SHAFT	SHAFT
17	2	BUSHING	BUSHING
18	2	PS.37	PULLEY SPACER 3/8"ID
19	1	LPCABLE	LEG PRESS CABLE
20	2	HEX.31x1.5PT	HEX HEAD BOLT 5/16" X 1 1/2" PARTIAL THREAD
21	1	HEX.31x2.5PT	HEX HEAD BOLT 5/16" X 2 1/2" PARTIAL THREAD
22	2	HEX.37x1PT	HEX HEAD BOLT 3/8" X 1" PARTIAL THREAD
23	4	HEX.37x2PT	HEX HEAD BOLT 3/8" X 2" PARTIAL THREAD
24	1	HEX.37x2.5PT	HEX HEAD BOLT 3/8" X 2 1/4" PARTIAL THREAD
25	4	HEX.37x4PT	HEX HEAD BOLT 3/8" X 4" PARTIAL THREAD
27	2	FAH.37X.5FT	FLAT ALLEN HEAD 5/16" X 1/2" FULL THREAD
28	4	AH.31X.37FT	ALLEN HEAD 5/16" X 5/16" FULL THREAD
29	1	SHB.31X.5FT	SOCKET HEAD BOLT 5/16" X 1/2" FULL THREAD
30	2	WFLT.31	BIG WASHER 5/16"
31	4	SLW.31	SPRING LOCK WASHER 5/16"
32	26	WFLT.37	WASHER 3/8"
33	1	HEX.31X3.5PT	HEX HEAD BOLT 5/16" X 3 1/2" PARTIAL THREAD
40	15	NLN.37	NYLON LOCK NUT 3/8"
41	1	LN.37	LOCK NUT 3/8"
42	8	HEX.37x4.37PT	HEX HEAD BOLT 3/8" X 4 3/8" PARTIAL THREAD
43	4	WFLT.31	WASHER 5/16"
44	1	SLW.31	SPRING LOCK WASHER 5/16"

Key #, Part #, and Description are required when ordering parts.

# EXPLODED VIEW DIAGRAM PLPX



1900 S. Des Plaines Ave.  
Forest Park, IL 60130  
1 (800) 556-3113  
Hours: M-F 8:30 - 5:00 CST

# **POWERLINE®**

© Copyright 2003. Body-Solid. All rights reserved. Body-Solid reserves the right to change design and specifications when we feel it will improve the product. Body-Solid machines maintain several patented and patent pending features and designs. All rights reserved on all design patents and utility patents.